

# EOCR-SSD

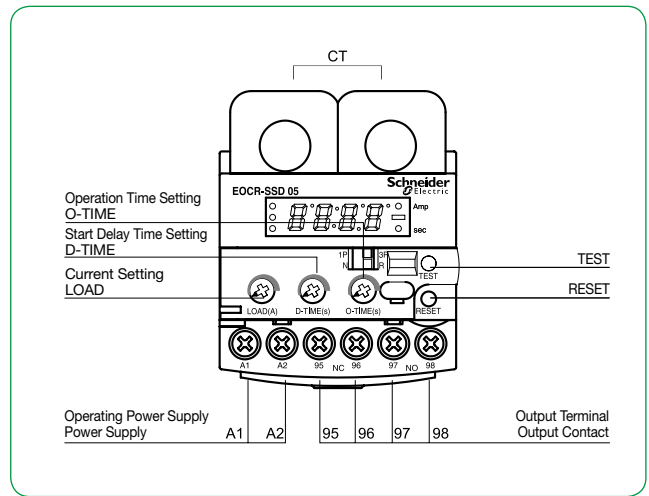

## Main Features

- The compact design enables installation in a narrow space (can be replaced with an SS type on 1:1 basis)
- Accurate display of operating current via the frontal LED display (the higher current value will be displayed, whichever is higher between L1 and L3)
- LED window displays the trip cause when a trip occurs
- Accurate phase loss protection (3 sec)
- Easy application: Can select between single-phase (1P) or 3-phase (3P) using DIP SW.
- Works well with an inverter system: 20~200Hz
- Can select contact output[Fail safe(N)/Non-fail safe(R)]: Maximum convenience for sequence configuration
- Easy installation, with DIN Rail and Panel Mounting compatibility

## Protection Function

Protection Function	Operation Time
Over Current	Operates after O-Time
Phase Loss	Operates within 3 sec
Locked Rotor	Immediately operates if 200% or more of the set current continues after D-Time

## Trip Cause Display and Check Method

Operation Display (Trip Indication)		
Trip Cause	Trip Cause Display	Description
Over Current		Trips after detecting the over current of 10A during operation.
Phase Loss		Trips by L1 (R) phase loss.
		Trips by L2 (S) phase loss.
		Trips by L3 (T) phase loss.
Locked Rotor		Trips when a stall is detected.

## Specifications

Functions and Characteristics			Specifications
<b>Current Setting</b>	Over Current	5	0.5~6A
		30	3~30A
		60	10~60A
		60A or higher	Use 05Type in combination with an external CT
<b>Time Setting</b>	Start Delay Time	D-Time	1~30 sec
	Operation Time	O-Time:	0.5/1~10 sec
<b>Reset</b>			Manual(instant) reset/electrical reset (power supply cut)
<b>Operation Time Characteristic</b>	Over Current		Definite
<b>Error Tolerance</b>	Current		±5%
	Time		±0.2 sec
<b>Usage Environment</b>	Temperature	Operation	-20℃~60℃
		Storage	-30℃~80℃
	Humidity		30~85% RH without icing
<b>Operating Power Supply</b>	24		AC/DC24V
	110		AC110V±15%, 50/60Hz
	220		AC220V±15%, 50/60Hz
	440		AC440V±15%, 50/60Hz
<b>Output contact</b>	2-SPST (1a1b)		AC250V/3A resistive load
<b>Insulation</b>	Resistance	Between circuit and case	10MΩ at DC500V
		Withstanding Voltage	Between circuit and case
		Between contacts	1.0kV, 60Hz for 1 min
		Between circuits	2.0kV, 60Hz for 1 min
<b>Attachment Method</b>			35mm DIN Rail or Panel
<b>Electrostatic Discharge</b>	IEC61000-4-2	Level 3 :	Air Discharge : ±8kV
			Contact Discharge : ±6kV
<b>Radiated Electromagnetic Field Disturbance</b>	IEC61000-4-3	Level 3 :	10V/m, 150MHz & 450MHz
<b>EFT/Burst</b>	IEC61000-4-4	Level 3 :	±2KV, 1 Min
<b>Surge</b>	IEC61000-4-5	Level 3 :	1.2×50μs, ±4kV(0°, 90°, 180°, 270°)
<b>Conducted Disturbance</b>	IEC61000-4-6	Level 3 :	10V, 0.15~80MHz
<b>1MHz Burst Disturbance</b>	IEC61000-4-12	Level 3 :	2.5kV, 1MHz
<b>Conducted Emission</b>	EN55011	Level 3 :	Class A (Conducted & Radiated)

## Function Setting Sequence and Settings Menu

### • Configure the setting as follows before operating the motor:













- Operating Current Setting
  - Set it on the motor's rated current, but in order to protect the machine as well as the load, check the active load current with the digital indicator under normal load state after the startup is complete, and set it to be higher (110%~125%) than the operating current by turning the LOAD knob.
- Start Delay Time
  - ① Set it to max and start the motor.
  - ② After starting the motor, check the current while measuring the time it takes for the operating current to return to normal current. Set the start delay time to about 1 sec longer than the measured time using the D-TIME knob. (For Y-Δ startup, set it to 1~2 sec longer than the full start timer)
- Operating Time: Set the time it takes for the relay to operate from the moment the current flow exceeds the current set value using the O-TIME Knob.

Sequence	Items	Display	Setting Method	Notes
1	Over Current Setting		05 Type : 0.5A~6A 30 Type : 3A~30A 60 Type : 10A~60A	<ul style="list-style-type: none"> <li>• 0.5~6A : Changes in increments of 0.1A</li> <li>• 3~30A : Changes in increments of 1A</li> <li>• 10~60A : Changes in increments of 1A</li> </ul>
2	Start Delay Time Setting		1~30 sec	<ul style="list-style-type: none"> <li>• Changes in increments of 1 sec</li> </ul>
3	Over Current Operation Time Setting		0.5, 1~10sec	<ul style="list-style-type: none"> <li>• 0.5sec</li> <li>• 1~10 sec (Changes in increments of 1sec)</li> </ul>
4	TEST Function		After 3 sec + set O-Time is elapsed, displays END	After 3 sec + set O-Time,  TEST is no longer possible during operation.

# EOCR-SSD

## TEST Function

Each set value and the health status of the relay can be checked by pressing the TEST button.

Before the motor starts		After the motor starts
<p>The set value for each setting mode can be checked each time the TEST button is pressed. Test function is completed after going through the TEST mode, which checks the set values and inspects the health status of the EOCR itself.</p>		<p>Each time the TEST button is pressed, the set value for each setting mode can be checked.</p>
 <p>↓ (RESET) pressed</p>	<p><u>Current Display</u> Displays higher current value between L1 and L2 Before startup: In=0A, after startup: In=3.85A</p>	 <p>↓ (TEST) pressed</p>
 <p>↓ (RESET) pressed</p>	<p><u>Current Setting Mode</u> Current Setting (Is)=4.5A</p>	 <p>↓ (TEST) pressed</p>
 <p>↓ (RESET) pressed</p>	<p><u>Start Delay Time (D-TIME) Setting Mode</u> D-TIME=10 sec</p>	 <p>↓ (TEST) pressed</p>
 <p>↓ (RESET) pressed</p>	<p><u>Operation Time (O-TIME) Setting Mode</u> O-TIME=5 sec</p>	 <p>↓ (TEST) pressed</p>
 <p>↓ (TEST) 3 sec + set O-Time elapsed</p>	<p>Self-TEST begins</p>	<p>Does not perform in Relay Test mode in order to prevent a trip accident during operation.</p> <p>⇩</p>
 <p>↓ (RESET) pressed</p>	<p><u>Self-TEST in progress</u> Self-TEST completed After setting O-TIME, the contact of inner Relay is passed and the self-TEST is completed.</p>	<p>Returns to operating current display mode after 10~20 sec in any mode</p> <p>↓</p>
	<p>Returns to current display mode if the Reset button is pressed</p>	

# EOCR-SSD

## Over Current Operation Time Characteristic Curve

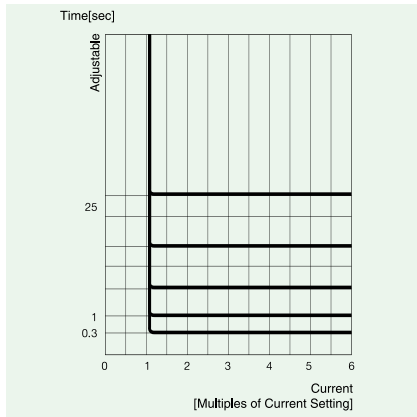
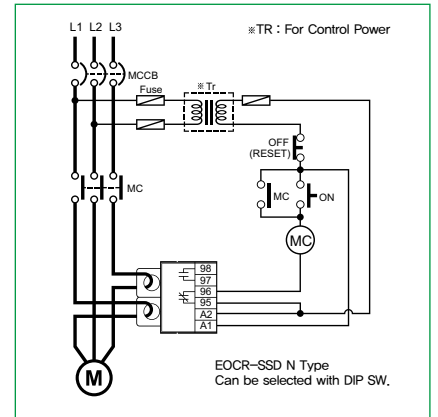
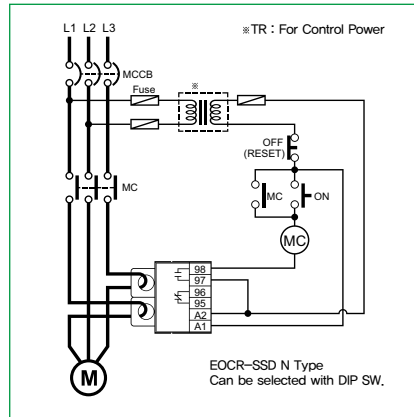
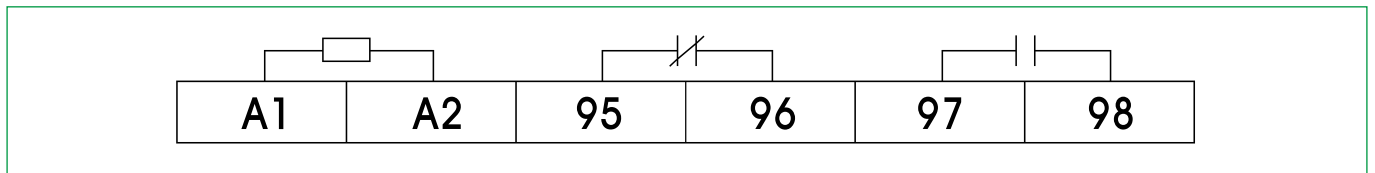

Table 1. Over Current Protection Definite Operation Characteristic Curve

## Example Wiring Diagram



## I/O (Input/Output) Terminal Diagram



## Dimensions Diagram

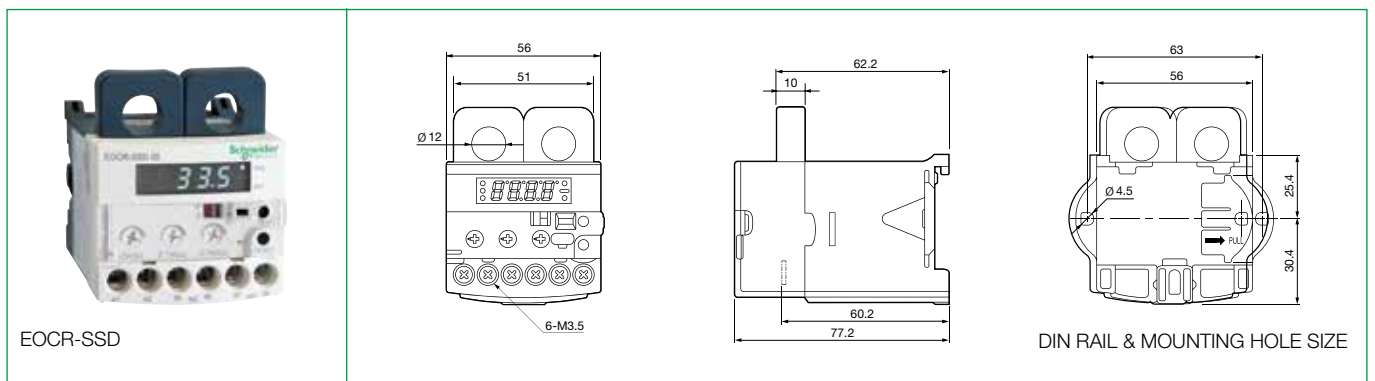

# EOCR-SSD

## Ordering Specifications

Reference		Current Range [A]	Output Contact	Operating Power Supply		Notes	
				Voltage [V]	Frequency [Hz]		
 EOCR-SSD	EOCRSSD	-05DB	5	b-a	DC/AC 24V	-	-
		-30DB	30	b-a	DC/AC 24V	-	-
		-60DB	60	b-a	DC/AC 24V	-	-
		-05DF7	5	b-a	AC 110V	50/60	-
		-30DF7	30	b-a	AC 110V	50/60	-
		-60DF7	60	b-a	AC 110V	50/60	-
		-05DM7	5	b-a	AC 220V	50/60	-
		-30DM7	30	b-a	AC 220V	50/60	-
		-60DM7	60	b-a	AC 220V	50/60	-
		-05DR7	5	b-a	AC 440V	50/60	-
		-30DR7	30	b-a	AC 440V	50/60	-
		-60DR7	60	b-a	AC 440V	50/60	-
		-D1DB	100:05:00	b-a	DC/AC 24V	-	Rectangular CT Combination
		-DHDB	150:05:00	b-a	DC/AC 24V	-	Rectangular CT Combination
		-D2DB	200:05:00	b-a	DC/AC 24V	-	Rectangular CT Combination
		-D3DB	300:05:00	b-a	DC/AC 24V	-	Rectangular CT Combination
		-D4DB	400:05:00	b-a	DC/AC 24V	-	Rectangular CT Combination
		-D1DF7	100:05:00	b-a	AC 110V	50/60	Rectangular CT Combination
		-DHDF7	150:05:00	b-a	AC 110V	50/60	Rectangular CT Combination
		-D2DF7	200:05:00	b-a	AC 110V	50/60	Rectangular CT Combination
		-D3DF7	300:05:00	b-a	AC 110V	50/60	Rectangular CT Combination
		-D4DF7	400:05:00	b-a	AC 110V	50/60	Rectangular CT Combination
		-D1DM7	100:05:00	b-a	AC 220V	50/60	Rectangular CT Combination
		-DHDM7	150:05:00	b-a	AC 220V	50/60	Rectangular CT Combination
		-D2DM7	200:05:00	b-a	AC 220V	50/60	Rectangular CT Combination
		-D3DM7	300:05:00	b-a	AC 220V	50/60	Rectangular CT Combination
		-D4DM7	400:05:00	b-a	AC 220V	50/60	Rectangular CT Combination
		-D1DR7	100:05:00	b-a	AC 440V	50/60	Rectangular CT Combination
		-DHDR7	150:05:00	b-a	AC 440V	50/60	Rectangular CT Combination
		-D2DR7	200:05:00	b-a	AC 440V	50/60	Rectangular CT Combination
	-D3DR7	300:05:00	b-a	AC 440V	50/60	Rectangular CT Combination	
	-D4DR7	400:05:00	b-a	AC 440V	50/60	Rectangular CT Combination	

## How to Order

To order an EOCR-SSD:

E O C R S S D - 0 5 D M 7

①      ②      ③

①	Current Range	5	0.5~6A
		30	3~30A
		60	10~60A
②	Output Contact State	D	b (95-96), a (97-98)
③	Operating Power Supply/ Frequency	B	AC/DC24V compatible
		F7	AC110V, 50/60Hz
		M7	AC220V, 50/60Hz
		R7	AC440V, 50/60Hz

※ For a CT combination type, please write an accessory code from the CT Order Codes separately.